

# ***MEC 800 Special***

**External oil-hydraulic operator for  
swinging gates of large dimensions.  
With separate motor-pump.**

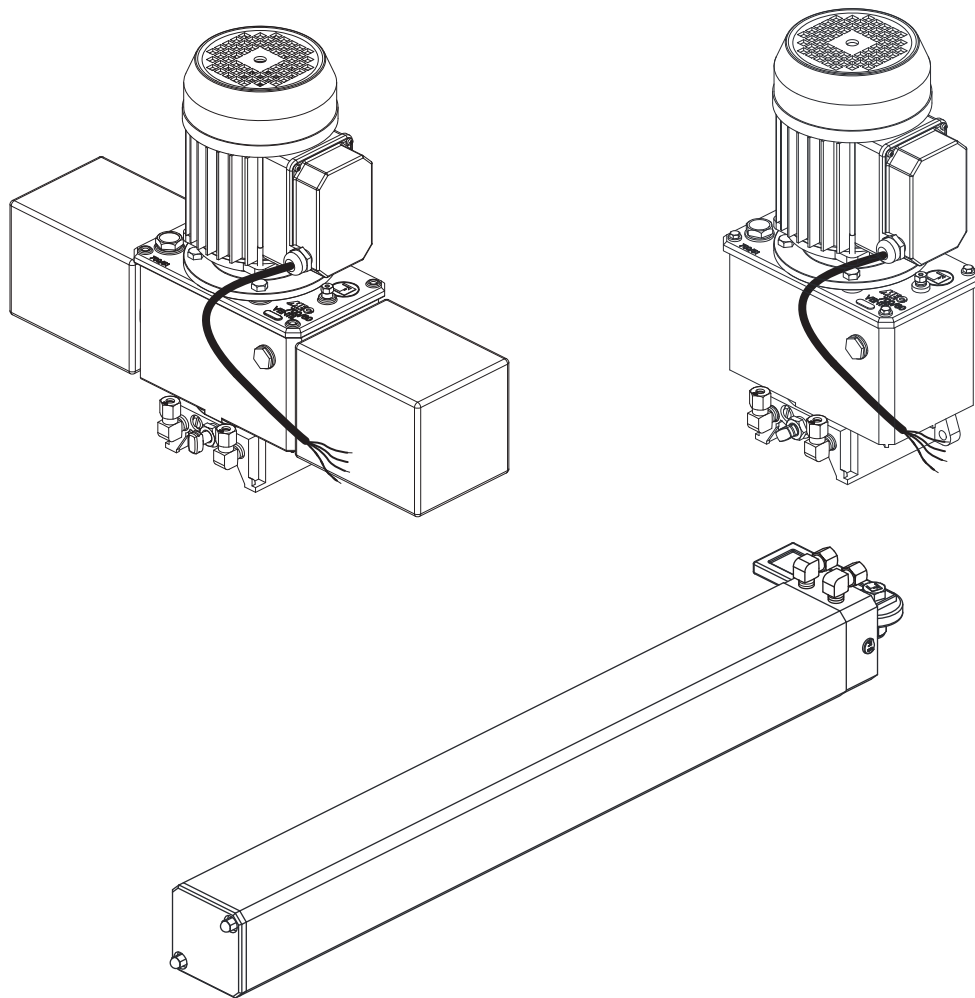

EN 13241  
EN 12453  
EN 12445

Made in Italy



## GENERAL WARNINGS FOR PEOPLE SAFETY

## THANK YOU

Thank you for purchasing a Fadini product. Please read these instructions carefully before using this appliance. The instructions contain important information which will help you get the best out of the appliance and ensure safe and proper installation, use and maintenance. Keep this manual in a convenient place so that you can always refer to it for the safe and proper use of the appliance.

## INTRODUCTION

This operator is designed for a specific scope of applications as indicated in this manual, including safety, control and signaling accessories as minimum required with Fadini equipment. □ Any applications not explicitly included in this manual may cause operation problems or damages to properties and people. □ Meccanica Fadini S.r.l. is not liable for damages caused by the incorrect use of the equipment, or for applications not included in this manual or for malfunctioning resulting from the use of materials or accessories not recommended by the manufacturer. □ The manufacturer reserves the right to make changes to its products without prior notice. □ All that is not explicitly indicated in this manual is to be considered not allowed.

## BEFORE INSTALLATION

Before commencing operator installation assess the suitability of the access, its general condition and the structure. □ Make sure that there is no risk of impact, crushing, shearing, conveying, cutting, entangling and lifting situations, which may prejudice people safety. □ Do not install near any source of heat and avoid contacts with flammable substances. □ Keep all the accessories able to turn on the operator (transmitters, proximity readers, key-switches, etc) out of the reach of the children. □ Transit through the access only with stationary operator. □ Do not allow children and/or people to stand in the proximity of a working operator. □ To ensure safety in the whole movement area of a gate it is advisable to install photocells, sensitive edges, magnetic loops and detectors. □ Use yellow-black strips or proper signals to identify dangerous spots. □ Before cleaning and maintenance operations, disconnect the appliance from the mains by switching off the master switch. □ If removing the actuator, do not cut the electric wires, but disconnect them from the terminal box by loosening the screws inside the junction box.

## INSTALLATION

All installation operations must be performed by a qualified technician, in observance of the Machinery Directive 2006/42/CE and safety regulations EN 12453 - EN 12445. □ Verify the presence of a thermal-magnetic circuit breaker 0,03 A - 230 V - 50 Hz upstream the installation. □ Use appropriate objects to test the correct functionality of the safety accessories, such as photocells, sensitive edges, etc. □ Carry out a risk analysis by means of appropriate instruments measuring the crushing and impact force of the main opening and closing edge in compliance with EN 12445. □ Identify the appropriate solution necessary to eliminate and reduce such risks.

□ In case where the gate to automate is equipped with a pedestrian entrance, it is appropriate to prepare the system in such a way to prohibit the operation of the engine when the pedestrian entrance is used. □ Apply safety nameplates with CE marking on the gate warning about the presence of an automated installation. □ The installer must inform and instruct the end user about the proper use of the system by releasing him a technical dossier, including: layout and components of the installation, risk analysis, verification of safety accessories, verification of impact forces and reporting of residual risks.

## INFORMATION FOR END-USERS

The end-user is required to read carefully and to receive information concerning only the operation of the installation so that he becomes himself responsible for the correct use of it. □ The end-user shall establish a written maintenance contract with the installer/maintenance technician (on -call). □ Any maintenance operation must be done by qualified technicians. □ Keep these instructions carefully.

## WARNINGS FOR THE CORRECT OPERATION OF THE INSTALLATION

For optimum performance of system over time according to safety regulations, it is necessary to perform proper maintenance and monitoring of the entire installation: the automation, the electronic equipment and the cables connected to these. □ The entire installation must be carried out by qualified technical personnel, filling in the Maintenance Manual indicated in the Safety Regulation Book (to be requested or downloaded from the site [www.fadini.net/supporto/downloads](http://www.fadini.net/supporto/downloads)). □ Operator: maintenance inspection at least every 6 months, while for the electronic equipment and safety systems an inspection at least once every month is required. □ The manufacturer, Meccanica Fadini S.r.l., is not responsible for non-observance of good installation practice and incorrect maintenance of the installation.

## DISPOSAL OF MATERIALS

Dispose properly of the packaging materials such as cardboard, nylon, polystyrene etc. through specializing companies (after verification of the regulations in force at the place of installation in the field of waste disposal). Disposal of electrical and electronic materials: to remove and dispose through specializing companies, as per Directive 2012/19/UE. Disposal of substances hazardous for the environment is prohibited.



## CE DECLARATION OF CONFORMITY of the manufacturer:

Meccanica Fadini S.r.l. (Via Mantova, 177/A - 37053 Cerea - VR - Italy) declares under own responsibility that:

**Mec 800 Special** complies with the 2006/42/CE Machinery Directive, and also that it is sold to be installed in an "automatic system", along with original accessories and components as indicated by the manufacturing company. An automatic gate operator is, by law, a "machinery" and therefore the installer must fit the equipment with all of the applicable safety norms. The installer is also required to issue the installer's Declaration of Conformity. The manufacturer is not liable for possible incorrect use of the product. The product complies with the following specific norms: analysis of the risks and subsequent action to cure them as per EN 12445 and EN 12453, Low Voltage Directive 2014/35/UE, Electromagnetic Compatibility 2014/30/UE. In order to certify the product, the manufacturer declares under own responsibility the compliance with the EN 13241-1 PRODUCT NORMS.

Meccanica Fadini S.r.l.  
Director, in charge

## CE DECLARATION OF CONFORMITY of the manufacturer:

Meccanica Fadini S.r.l. (Via Mantova, 177/A - 37053 Cerea - VR - Italy) declares under own responsibility that:

**Mec 700/80 Ventil** complies with the 2006/42/CE Machinery Directive, and also that it is sold to be installed in an "automatic system", along with original accessories and components as indicated by the manufacturing company. An automatic gate operator is, by law, a "machinery" and therefore the installer must fit the equipment with all of the applicable safety norms. The installer is also required to issue the installer's Declaration of Conformity. The manufacturer is not liable for possible incorrect use of the product. The product complies with the following specific norms: analysis of the risks and subsequent action to cure them as per EN 12445 and EN 12453, Low Voltage Directive 2014/35/UE, Electromagnetic Compatibility 2014/30/UE. In order to certify the product, the manufacturer declares under own responsibility the compliance with the EN 13241-1 PRODUCT NORMS.

Meccanica Fadini S.r.l.  
Director, in charge

**PRODUCT GENERAL DESCRIPTION**

MEC 800 Special is an oil-hydraulic system for external application, designed to open and close large and particularly heavy swinging gates (even up to 1.200 kg), thanks to a separate oil-hydraulic motor pump equipped with an air-cooled motor of high power. Being an oil-hydraulic product, it incorporates all the main advantages peculiar to these systems such as smooth movements and adjustable thrust power by means of high/low pressure valves to meet any gate design and requirements.

**MEC 800 Special actuator is combined to MEC 700/80 Ventil oil-hydraulic motor pump; the respective main features are listed down below:**

<p><b>MEC 800 Special:</b></p> <ul style="list-style-type: none"> <li>- stroke (standard): 280 and 400 mm</li> <li>- stroke (on demand): 500, 600, 700, 800, 900, 1.000 mm</li> <li>- braking in closing, in opening/closing or non braking</li> </ul>	<p><b>MEC 700/80 Ventil:</b></p> <ul style="list-style-type: none"> <li>- single tank or double tank (depending on the number of MEC 800 Special actuators installed per gate leaf and piston stroke)</li> <li>- with hydraulic locking device or reversible (without hydraulic locking device)</li> <li>- with P6 pump or fast version P12 pump</li> </ul>
--	---

For the MEC 800 Special to work as an automatic system it is required that an electronic control box type Elpro be fitted externally in a sheltered place. Operations can be selected to be either fully automatic or semiautomatic (closing by pulse), depending on the user's requirements.

The system is designed to work together with accessories that ensure possibility of proper operations in full safety and reliability, making it suitable for any public or private applications.

**ACCESSORIES**

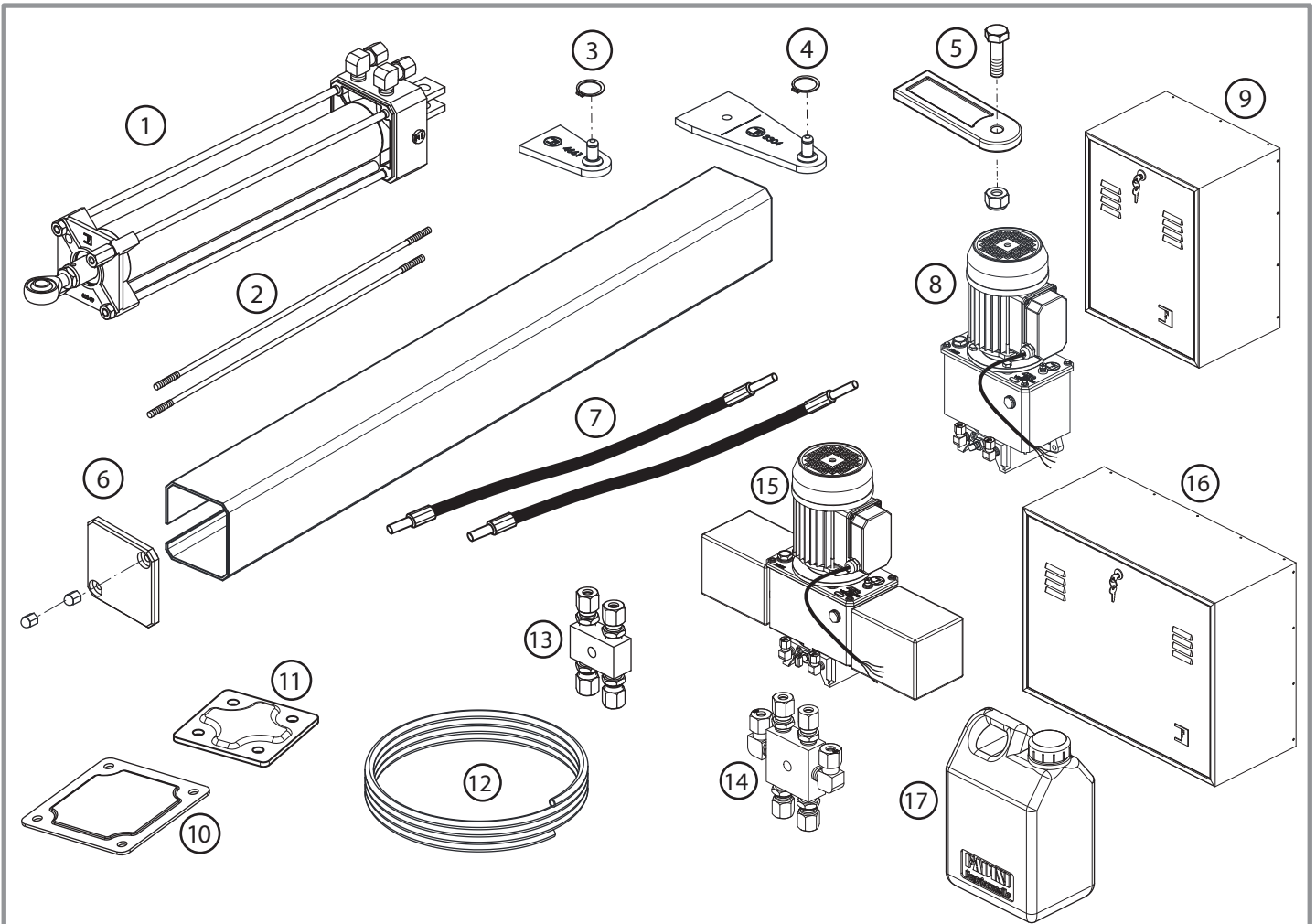

- |  |   |
|--|---|
| <ul style="list-style-type: none"> <li>1 - MEC 800 Special actuator</li> <li>2 - N° 2 x cover fastening tie rods</li> <li>3 - Gate fixing (with circlip) for 280 mm piston stroke version</li> <li>4 - Gate fixing (with circlip) for 400 to 1.000 mm piston stroke versions</li> <li>5 - Gate post fixing plates with M12x40 screw and M12 self-locking nut</li> <li>6 - Cover with aluminium end plug and fastening grommet nuts</li> <li>7 - N° 2 x 0,6 m hoses - item code No. 7018L</li> <li>8 - MEC 700/80 Ventil motor pump (it comes without oil inside)</li> <li>9 - Single tank motor pump casing - item code No. 7016L</li> </ul> | <ul style="list-style-type: none"> <li>10 - 150x150 mm patch plate, gate post rear fixing - item code No. 8311L</li> <li>11 - 84x84 mm patch plate, gate front fixing - item code No. 8312L</li> <li>12 - Ø 8 x 4 m copper pipe - item code No. 707L</li> <li>13 - 4-way pipe block - item code No. 7013L</li> <li>14 - 6-way pipe block (for 2 actuators)- item code No. 7038L</li> <li>15 - Double tank MEC 700/80 Ventil (it comes without oil inside)</li> <li>16 - Double tank motor pump casing - item code No. 7025L</li> <li>17 - 2 liters x oil tank - item code No. 708L (Pic. 8 refers)</li> </ul> |
|--|---|

Pic. 1

## ELECTRICAL WIRING DIAGRAM AND LAYOUT OF THE ACCESSORIES

Before installing MEC 800 Special it is advisable that preparatory work be carried out for all of the accessories required at least to ensure safety and proper control of the system.

General layout: it is the installer's care and responsibility to properly lay the pipes and tubes for the connections.

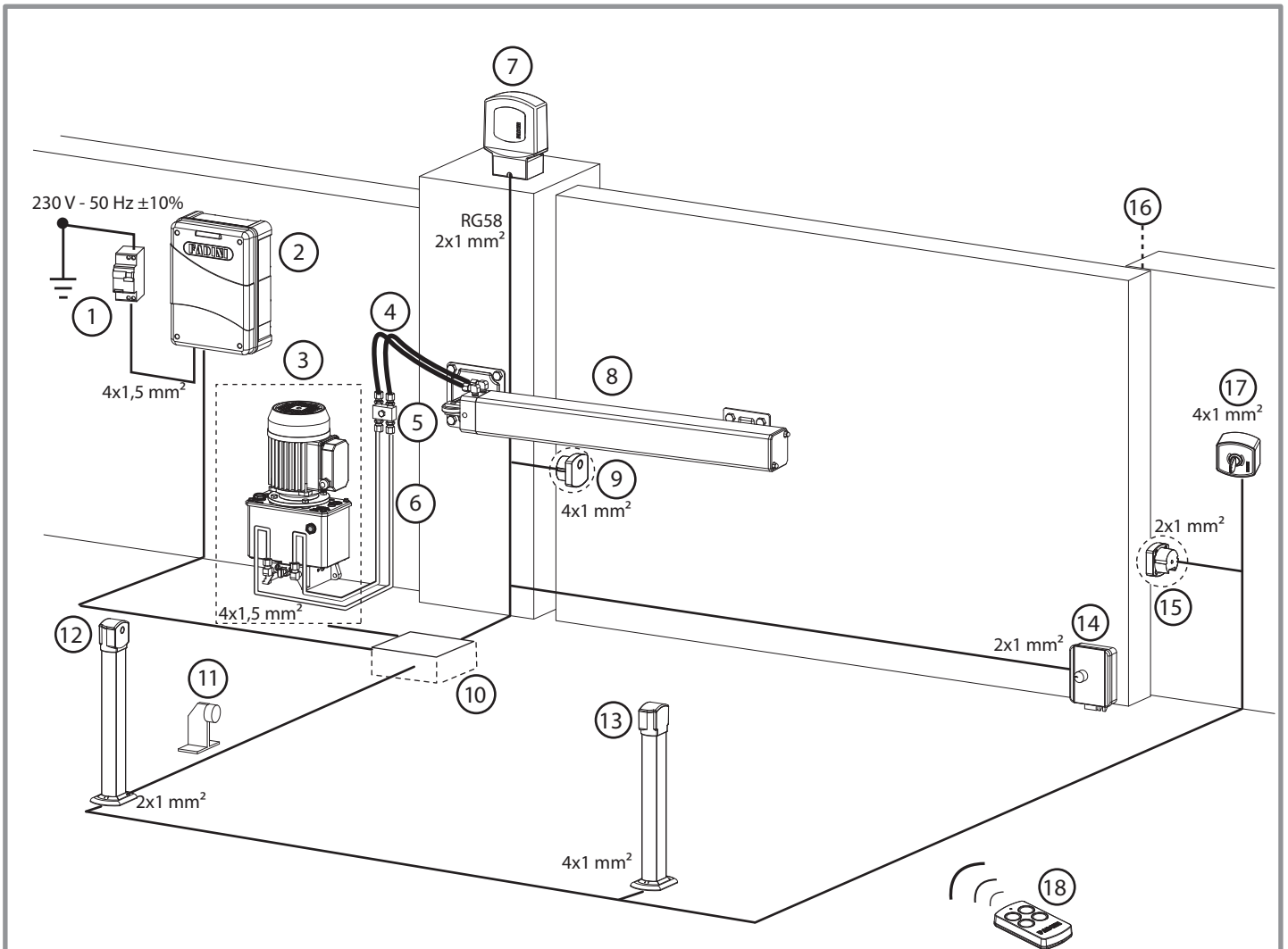

- 1 - 230 V - 50 Hz - 0,03 A magneto-thermal circuit breaker (cable section recommended 2,5 mm<sup>2</sup> beyond 100 m)
- 2 - Control box with plug-in radio receiver
- 3 - MEC 700/80 Ventil motor pump inside its protection housing
- 4 - Hoses
- 5 - 4-way pipe block
- 6 - Rigid copper pipes
- 7 - Flasher
- 8 - MEC 800 special actuator
- 9 - Photocell receiver
- 10 - Junction pit
- 11 - Gate stop in open position [A]
- 12 - Photocell transmitter on post mount
- 13 - Photocell receiver on post mount
- 14 - Gate electric lock
- 15 - Photocell transmitter
- 16 - Gate stop in closed position [A]
- 17 - Key-switch
- 18 - Hand held radio transmitter



[A]: NOTE VERY WELL: the gate stops in open and closed positions are most important for the correct and safe functioning of MEC 800 Special.

Pic. 2

INSTALLATION DISTANCES FOR THE GATE TO OPEN INWARDS

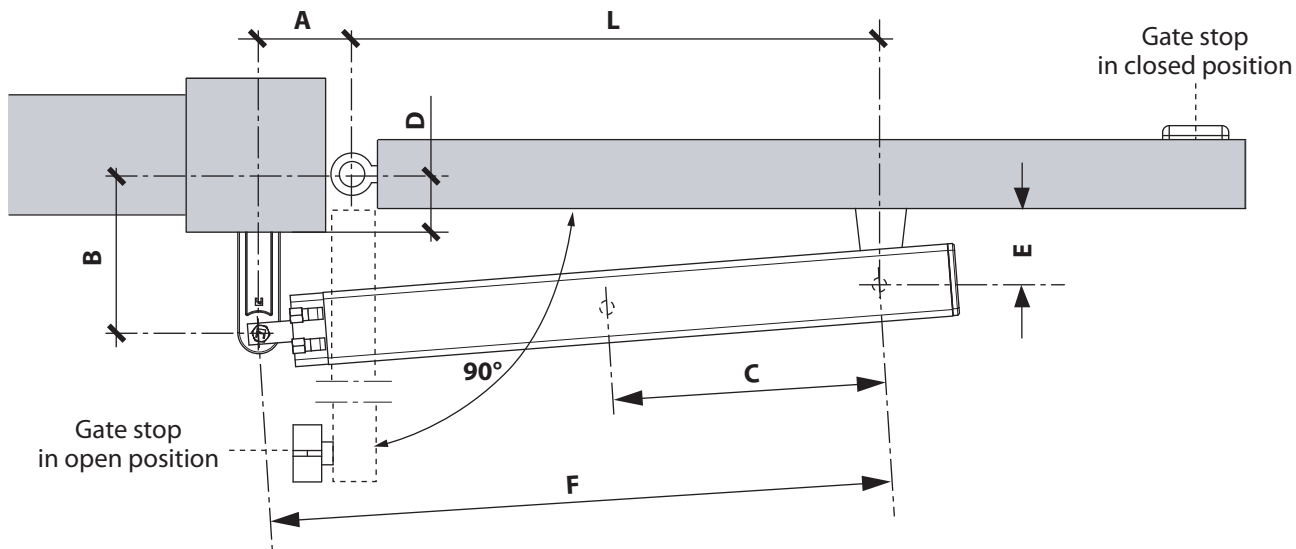

Installation distances in (mm) for opening 90°

Stroke C (mm)	A	B	D (max)	E	L	F
280	140	125	70	90	620	761
280 braking	110	130	70	80	625	735
400	180	200	130	110	820	1.002
400 braking	170	180	120	105	810	981
500	240	240	170	140	955	1.185
500 braking [B]	220	220	150	130	940	1.162
600 braking [B]	150	380	[B]	140	1.200	1.369
700 braking [B]	180	450	[B]	160	1.370	1.573
800 braking [B]	200	520	[B]	180	1.540	1.769
900 braking [B]	230	580	[B]	200	1.700	1.963
1.000 braking [B]	240	670	[B]	220	1.890	2.173

[B]: The installation dimensions for the special strokes have been studied to take full advantage of the braking action in opening and closing cycles. In case any of the special strokes be required (braking version or non braking version), our technical team should be contacted and complete details of the gates provided for evaluation.

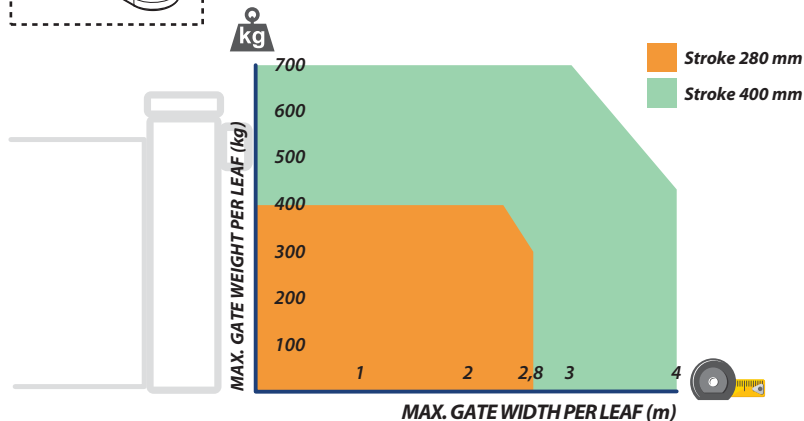
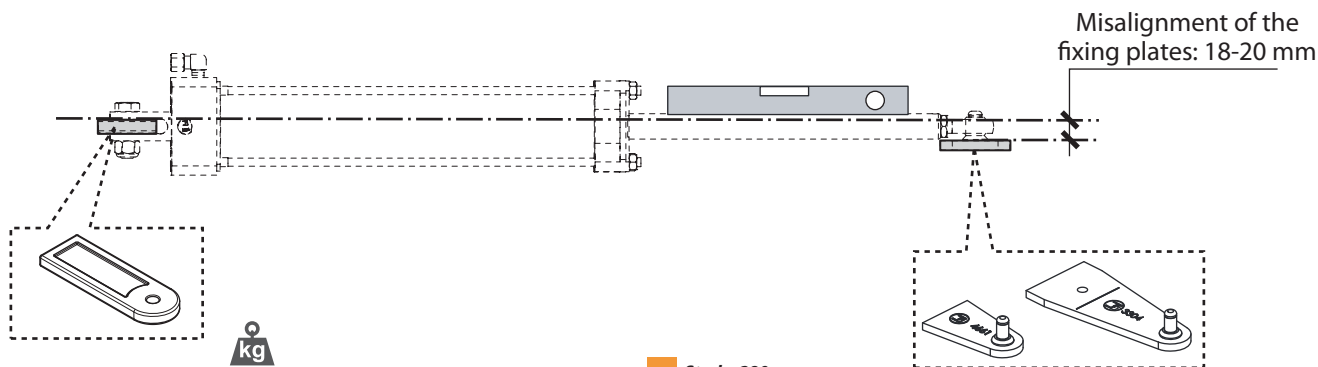

The gate structure, design (solid, in-filled), height and strong wind pressure may affect and decrease the indicated values. Make always sure the gate structure is adequate to automation.

Pic. 3

**PREPARING THE FIXING PLATES**

Fix the front and rear brackets to the respective patching plates in advance (Pic. 4), after checking the installation distances as indicated in Pic. 3.

English

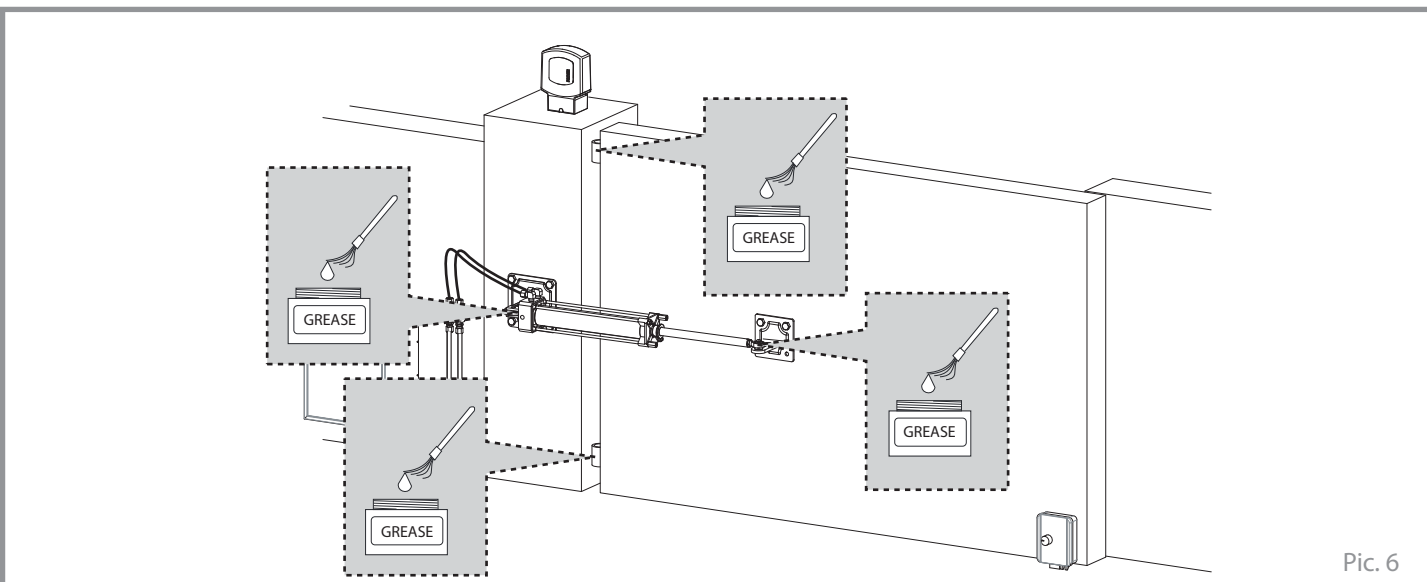
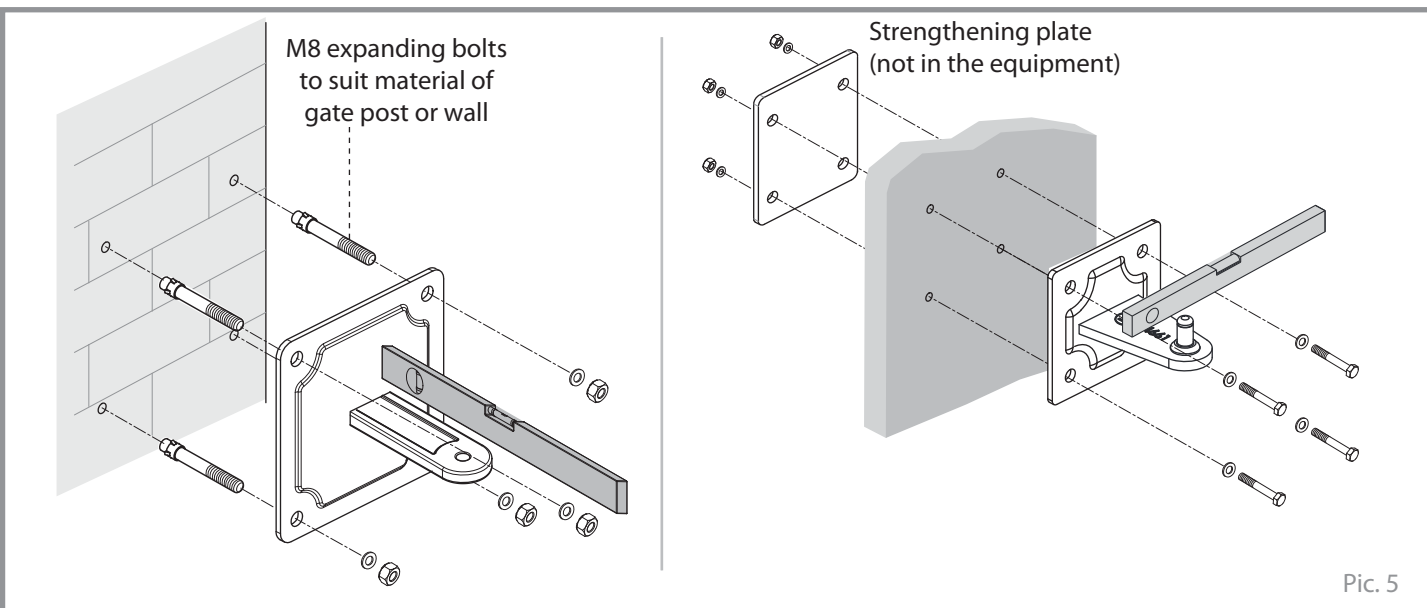
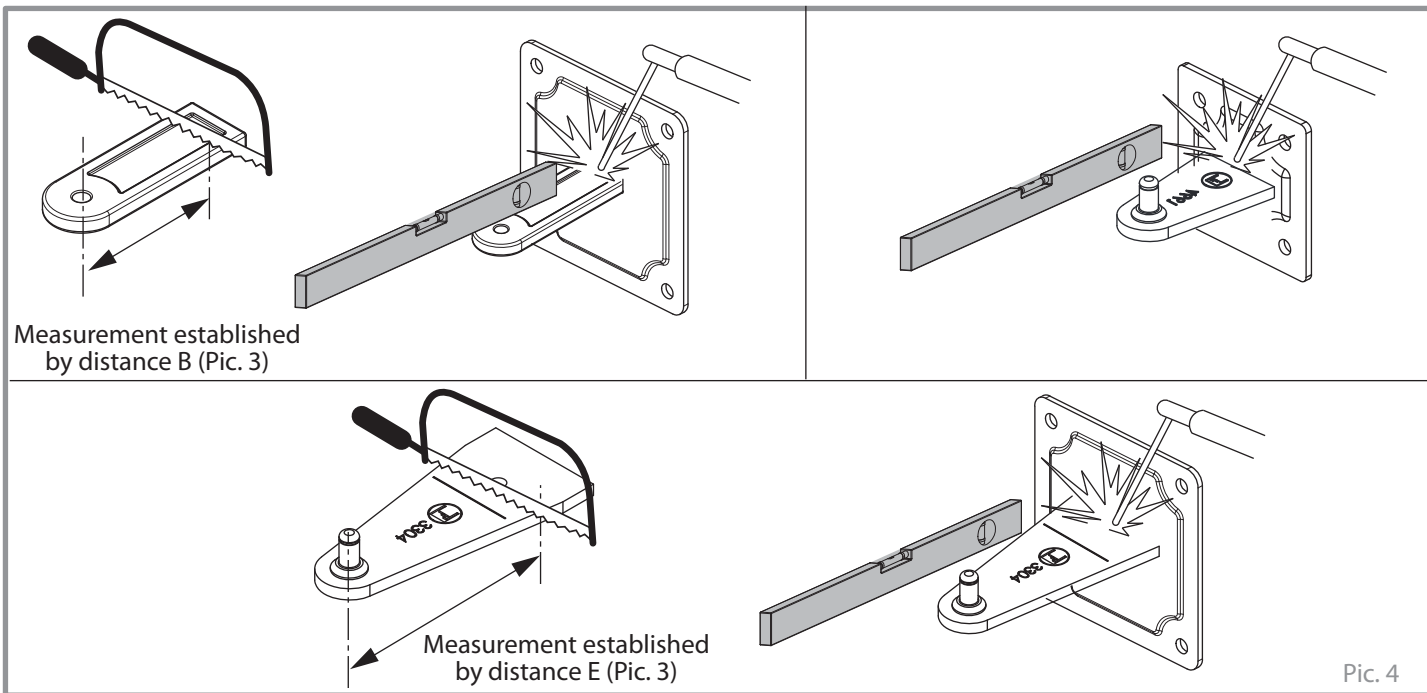

**FIXING THE OIL-HYDRAULIC MOTOR PUMP**

It is advisable to prepare the motor pump MEC 700/80 Ventil for a temporary installation along with the accessories (copper pipes, hoses, junction blocks, ...) in the most suitable way, but avoid any final fixing and oil filling.

The rigid copper pipes are to provide connection between the motor pump and the junction block, while the flexible hoses are to provide connection between the junction block and the actuator, sharp bends are to be avoided as well as rigidity, the hoses are still to stay flexible with the gate in open position.

It is recommended to carry out some open and close operations once the hoses are fitted and satisfied of the general installation, then go on with fixing and oil filling.

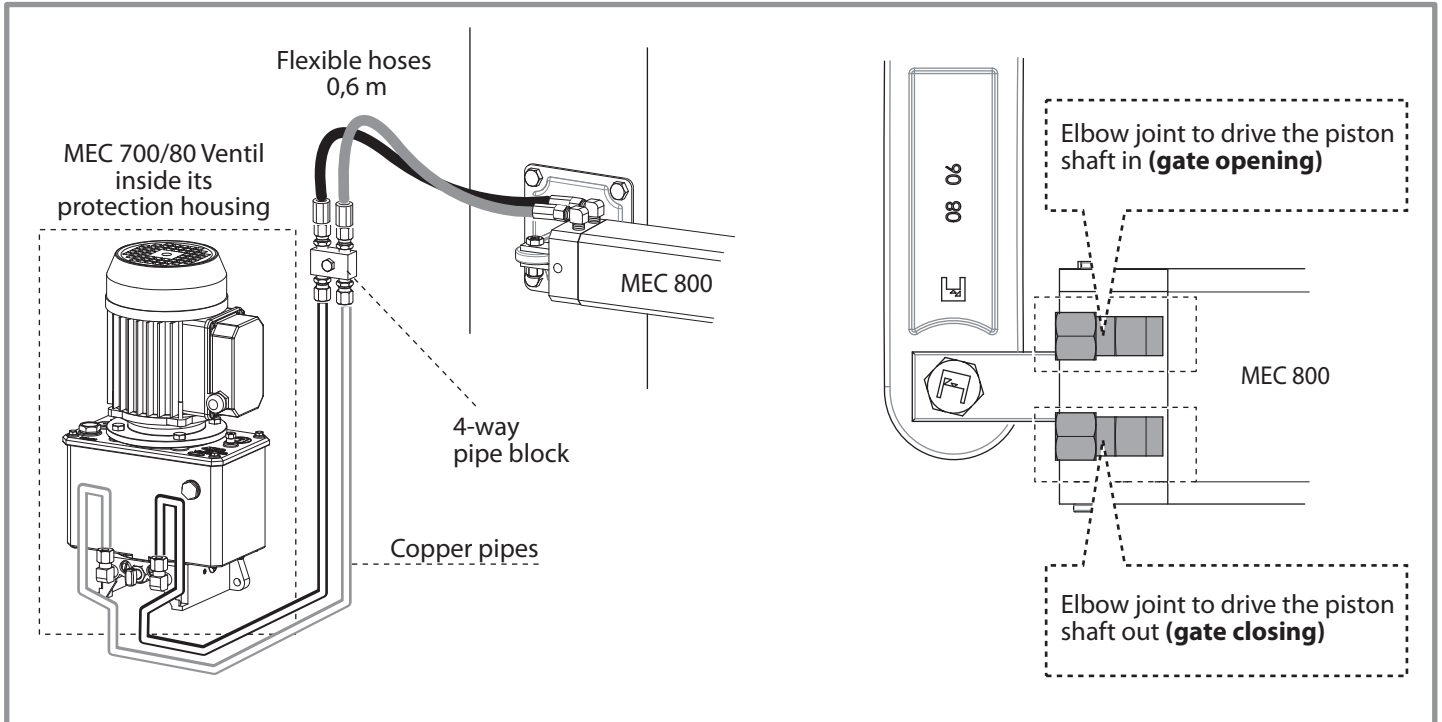

**When two MEC 800 Special actuators are mounted per gate leaf, it is required that MEC 700/80 ventil double tank version be used along with the 6-way pipe block: this one is to be positioned half distance between the two actuators to allow simultaneous oil delivery to both of them.**

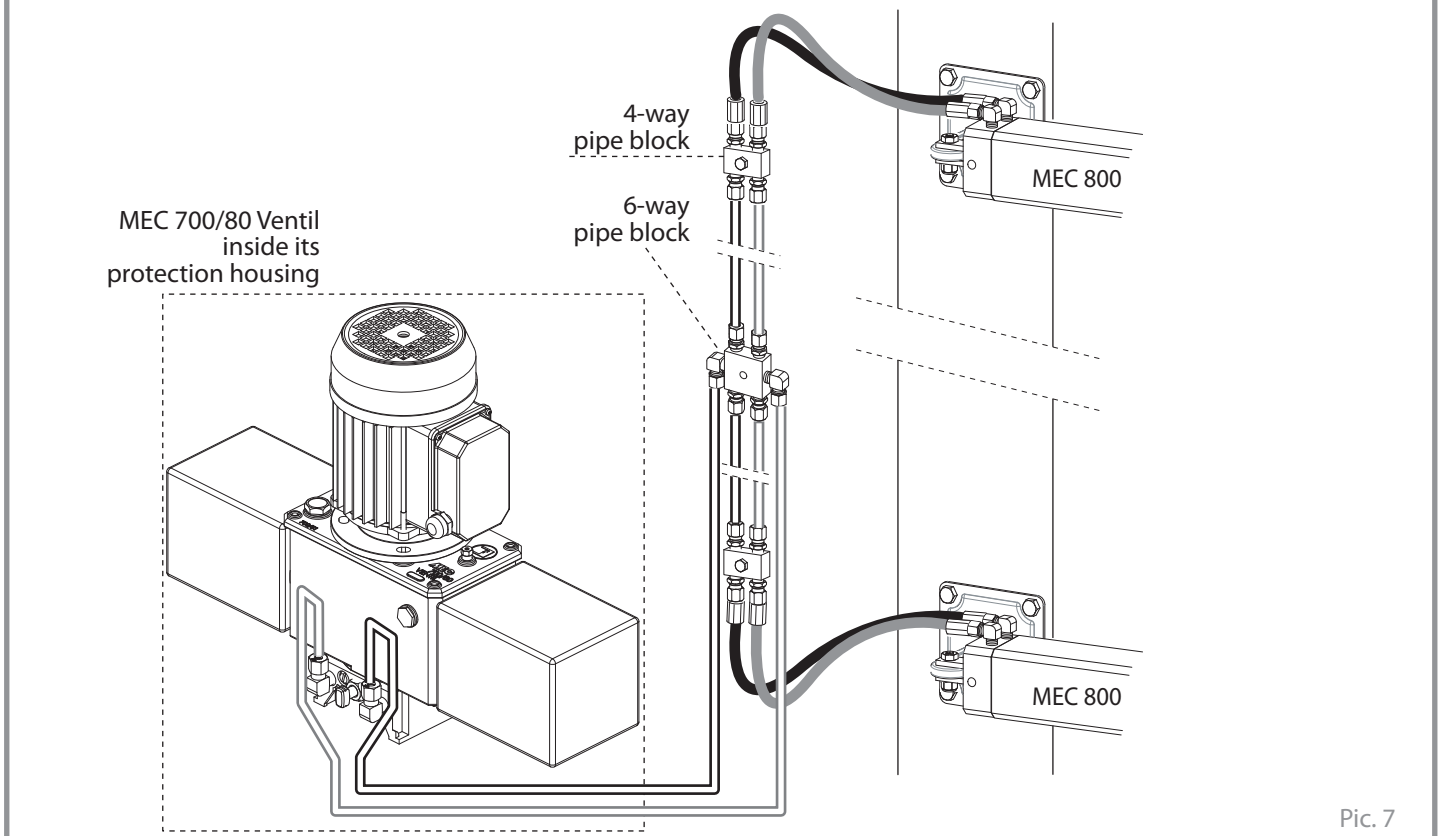

Pic. 7

**FILLING UP WITH OIL**

Once satisfied that piping (copper tubes and hoses) between actuator/s and motor pump is completed, make sure the all the nuts and joints of the oil-hydraulic system are properly tightened.

At this stage, filling up MEC 700/80 Ventil with oil can be the next step: it is advisable that this operation be carried out with the piston shaft fully out (gate closed).



**The motor pump MEC 700/80 Ventil comes without oil**

Remove this plug and fill in with oil

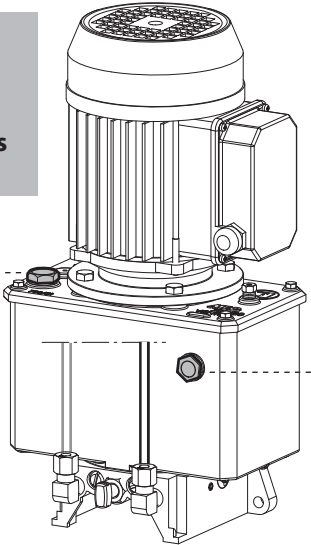

Oil level sight glass

stroke C (mm)	Liters of oil per actuator
280	0,5
400	0,8
500	1,0
600	1,2
700	1,4
800	1,6
900	1,8
1.000	2,0

**MEC 700/80 Ventil motor pump:**

single tank:	2,0
double tank:	4,5

*N.W. the amount of oil contained in the pipes between motor pump and actuator has not been specified.*

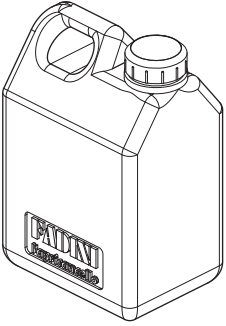

A 2 liters can of power oil

Pic. 8

Topping up. Electrically operate the piston and the motor pump (it is therefore required that the electrical connections to the control panel be executed first). In this way oil spreads through the entire hydraulic circuit: oil level in the motor pump can be seen to decrease through the sight glass on each movement of the piston; topping up to level is needed.

**THRUST POWER ADJUSTING**

Depending on gate type (weight, length, in-filled, etc. ...) thrust power on opening and closing can be adjusted by means of the screws controlling high and low pressure in MEC 700/80 Ventil motor pump.

By tightening the adjustment screws thrust power is increased.

**NOTE WELL:** it is most important that the pipes and hoses (ie. rigid and flexible oil-hydraulic connections) be properly connected to the motor pump and the actuator as indicated in Pic. 7. Since each adjustment screw controls the pressure to the nearest hydraulic joint, it is fundamental to make sure that the joint corresponding to the red screw be the one allowing for the gate to close, while the green one is to control oil flow for the gate to open.

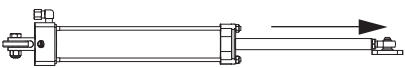

**Red adjusting screw** controls oil pressure of this joint: to be connected to the actuator joint driving the piston shaft out

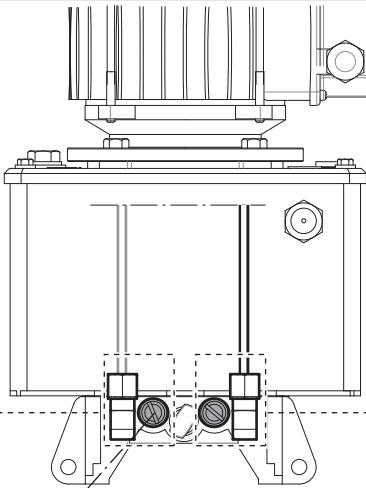

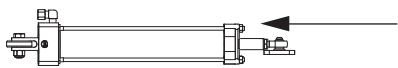

**Green adjusting screw** controls oil pressure of this joint: to be connected to the actuator joint driving the piston shaft in

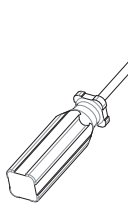

Pic. 9

**ADJUSTING THE HYDRAULIC BRAKING DEVICE**

For MEC 800 Special actuators fitted with a hydraulic braking device, it is required that braking speed be adjusted only in the closing phase (over the last centimeters of the piston travel), whereas in the opening phase braking is fixed. By a flat end screwdriver adjust the pin screw that is fitted on to the piston head.

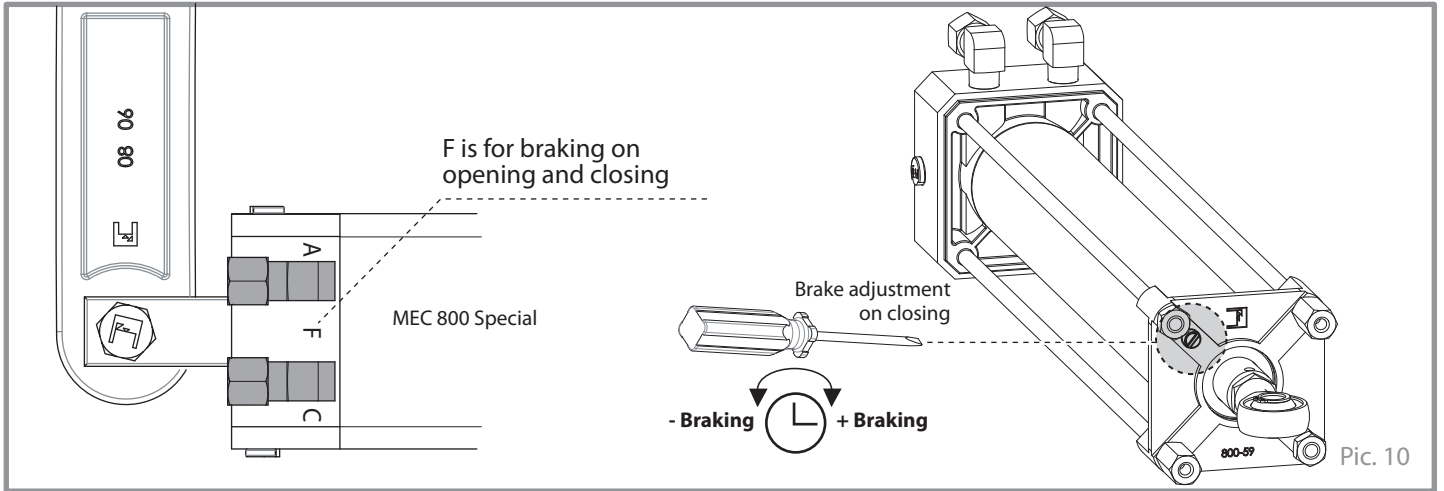

**INSTALLATIONS WITH FLOW REGULATOR**

The flow regulator is an optional device that allows for the operation speed to be adjusted as required all along the piston travel. It is specifically designed for those installations where heavy gates are involved and speed needs therefore control and variation on either opening or closing. The flow regulator is to be fitted directly on to the joints of the motor pump, inside its housing.

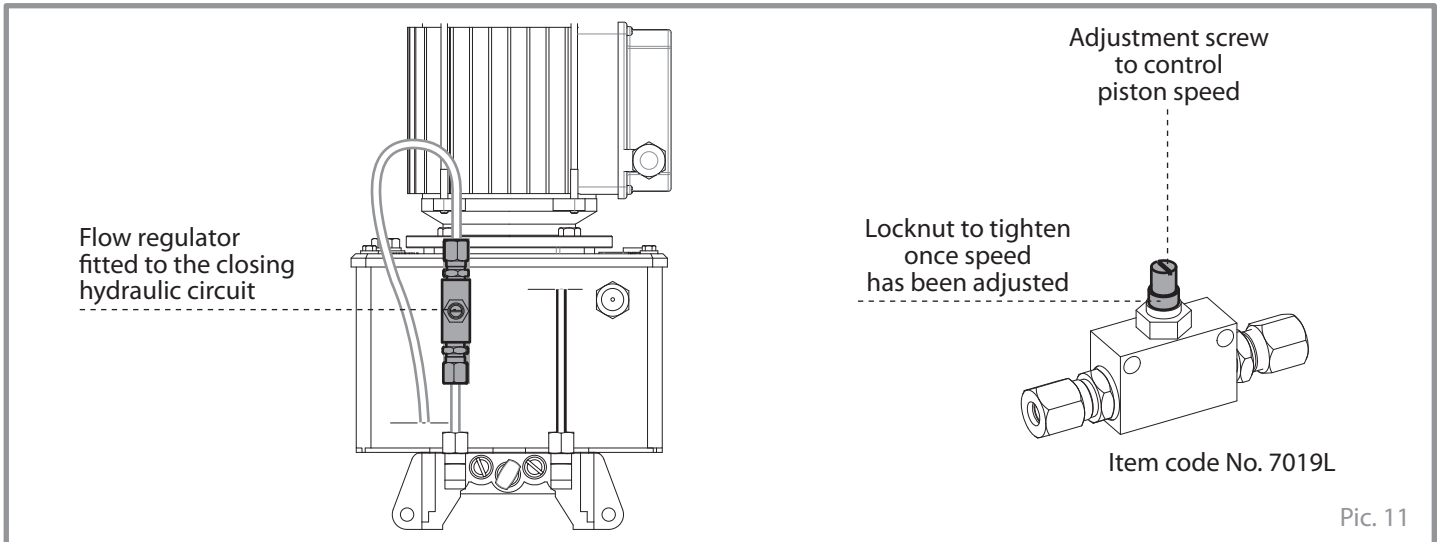

**FASTENING THE ACTUATOR COVER**

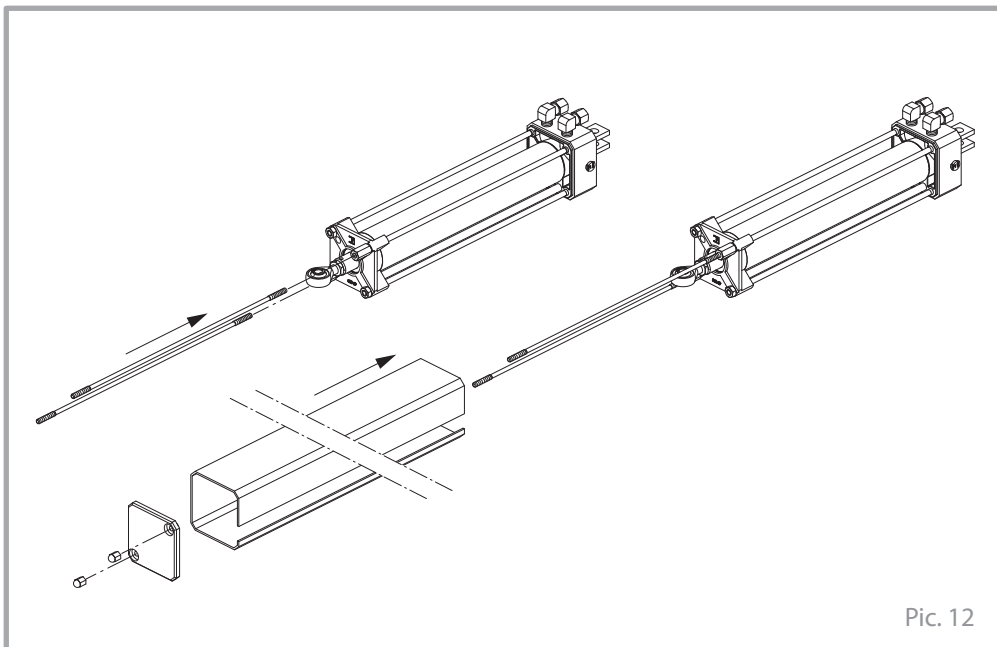

**ELECTRIC POWER SUPPLY**

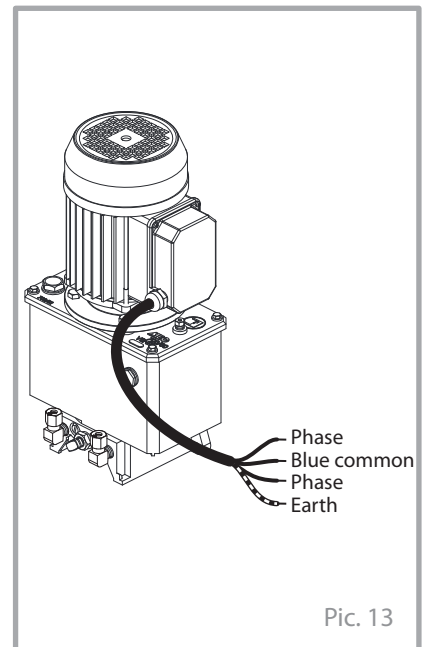

**HYDRAULIC UNIT ELECTRIC MOTOR**

Power output	0,37 kW (0,5 HP)
Supply voltage	230 Vac
Frequency	50 Hz
Absorbed power	510 W
Absorbed current	2,4 A
Motor rotation speed	1.350 rpm
Capacitor	20 µF
Intermittent service	S3

**MEC 700/80 VENTIL HYDRAULIC UNIT (single tank)**

P6 - Hydraulic pump capacity	1,6 l/min
P12 - Hydraulic pump capacity	2,6 l/min
Maximum pressure	40 atm
Oil type	Oil Fadini - Item 708L
Working temperature	-25 °C +80 °C [C]
Oil reservoir capacity	2 l
Static motor pump weight	10 kg
Protection standard	IP 65 (inside the enclosure)

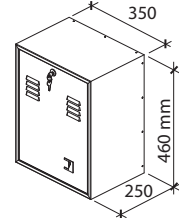
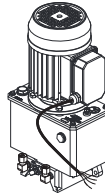

**MEC 700/80 VENTIL HYDRAULIC UNIT (double tank)**

P6 - Hydraulic pump capacity	1,6 l/min
P12 - Hydraulic pump capacity	2,6 l/min
Maximum pressure	40 atm
Oil type	Oil Fadini - Item 708L
Working temperature	-25 °C +80 °C [C]
Oil reservoir capacity	4,5 l
Static motor pump weight	16 kg
Protection standard	IP 65 (inside the enclosure)

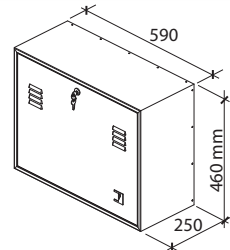
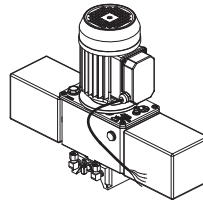

[C]: -40 °C with specific optional accessories (Ref. General Catalogue).

**OIL-HYDRAULIC RAM OPERATOR - STROKE 280 mm**

Piston stroke	280 mm
Piston diametre	50 mm
Shaft diametre	22 mm
Weight of Mec 800 Special	5,5 kg
Dimensions (length x width x height)	840x85x110 mm
Max gate weight per leaf	400 kg
Max gate width per leaf	2,8 m
Thrust power	0 ÷ 7.000 N

**PERFORMANCE**

Frequency of use	very intensive
Service cycle <i>(with installations having 2 actuators motor run time is twice as much)</i>	opening ~ 21 s dwell 15 s closing ~ 21 s dwell 15 s
Complete cycle time	~ 72 s
Complete cycles opening-dwell-closing-dwell	No. 50/hour

**P6 pump**

Frequency of use	very intensive
Service cycle <i>(with installations having 2 actuators motor run time is twice as much)</i>	opening ~ 21 s dwell 15 s closing ~ 21 s dwell 15 s
Complete cycle time	~ 72 s
Complete cycles opening-dwell-closing-dwell	No. 50/hour

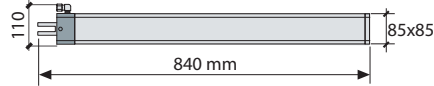
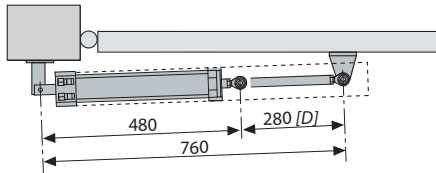

[D]: braking, piston stroke 250 mm

**OIL-HYDRAULIC RAM OPERATOR - STROKE 400 mm**

Piston stroke	400 mm
Piston diametre	50 mm
Shaft diametre	22 mm
Weight of Mec 800 Special	7,2 kg
Dimensions (length x width x height)	1.070x85x110 mm
Max gate weight per leaf	700 kg
Max gate width per leaf	4 m
Thrust power	0 ÷ 7.000 N

**PERFORMANCE**

Frequency of use	very intensive
Service cycle <i>(with installations having 2 actuators motor run time is twice as much)</i>	opening ~ 30 s dwell 20 s closing ~ 30 s dwell 20 s
Complete cycle time	~ 100 s
Complete cycles opening-dwell-closing-dwell	No. 36/hour

**P6 pump**

Frequency of use	very intensive
Service cycle <i>(with installations having 2 actuators motor run time is twice as much)</i>	opening ~ 30 s dwell 20 s closing ~ 30 s dwell 20 s
Complete cycle time	~ 100 s
Complete cycles opening-dwell-closing-dwell	No. 36/hour

**P12 pump**

Frequency of use	very intensive
Service cycle <i>(with installations having 2 actuators motor run time is twice as much)</i>	opening ~ 15 s dwell 20 s closing ~ 15 s dwell 20 s
Complete cycle time	~ 70 s
Complete cycles opening-dwell-closing-dwell	No. 50/hour

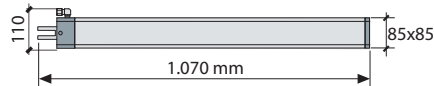
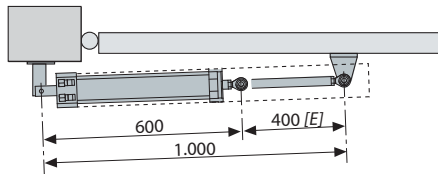

[E]: braking, piston stroke 370 mm

**PISTON STROKE SPECIAL VERSIONS**

stroke	oil volume	length L0	opening time
500	1,0 liters	1.280 mm	~ 37 s +b.t.
600	1,2 liters	1.480 mm	~ 45 s +b.t.
700	1,4 liters	1.680 mm	~ 51 s +b.t.
800	1,6 liters	1.880 mm	~ 59 s +b.t.
900	1,8 liters	2.080 mm	~ 66 s +b.t.
1.000	2,0 liters	2.280 mm	~ 73 s +b.t.

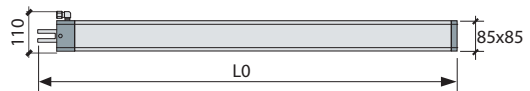

b.t.=breaking time

**MAINTENANCE RECORD**

hand over to the end user of the installation



English

Installation address:		Maintainer:	Date:
Installation type: Sliding gate <input type="checkbox"/> Folding door <input type="checkbox"/> Swinging gate <input checked="" type="checkbox"/> Road barrier <input type="checkbox"/> Over-head door <input type="checkbox"/> Bollard <input type="checkbox"/> Lateral folding door <input type="checkbox"/> ..... <input type="checkbox"/>		Operator model:	Quantity of models installed:
		Dimensions per gate leaf:	
		Weight per gate leaf:	Installation date:

**NOTE WELL:** this document must record any ordinary and extraordinary services including installation, maintenance, repairs and replacements to be made only by using Fadini original spare parts. This document, for the data included in it, must be made available to authorized inspectors/officers, and a copy of it must be handed over the end user/s.

The installer/maintainer are liable for the functionalities and safety features of the installation only if maintenance is carried on by qualified technical people appointed by themselves and agreed upon with the end user/s.

N°	Service date	Service description	Technical maintainer	End user/s
1				
2				
3				
4				
5				
6				

\_\_\_\_\_  
Stamp and signature  
installation technician/maintainer

\_\_\_\_\_  
Signed for acceptance  
end user  
buyer

hand over to the end user of the installation



**GUIDANCE FOR PROPER USE** (for the end user)**WARNINGS**

- Transit across the gate is allowed only if motor is stopped; stand at safe distance during opening and/or closing cycles of the gate.
- Do not touch any components of the system while the operator is working.
- Do not allow children and/or people to stand in the proximity of a working operator.
- Keep all the accessories able to turn on the operator (transmitters, proximity readers, key-switches, etc.) out of the reach of the children.
- Do not run the system in case of anomalies.

**DISPOSAL OF MATERIAL:** dispose properly of the packaging materials such as cardboard, nylon, polystyrene etc. through specializing companies (after verification of the regulations in force at the place of installation in the field of waste disposal). Disposal of electrical and electronic materials: to remove and dispose through specializing companies, as per Directive 2012/19/UE. Disposal of substances hazardous for the environment is prohibited.

**MAINTENANCE**

For optimum performance of system over time according to safety regulations, it is necessary to perform proper maintenance and monitoring of the entire installation: the automation, the electronic equipment and the cables connected to these. The entire installation must be carried out by qualified technical personnel. Operator: maintenance inspection at least every 6 months, while for the electronic equipment and safety systems an inspection at least once every month is required. The manufacturer, Meccanica Fadini S.r.l., is not responsible for non-observance of good installation practice and incorrect maintenance of the installation.

**Advice for the end user:**

- clear the site of materials that may have deposited in the equipment and hinder its correct functioning (such as rests of insects, foliage, stones, etc.); before carrying out this operation, switch off voltage supply;
- clean regularly the equipment by using a damp cloth. Do not use flammable substances such as alcohol, solvents or benzene: these substances may cause explosions and/or damage the system.

**RELEASING FOR MANUAL OPERATIONS**

On those installations with MEC 700/80 Ventil motor pump having the hydraulic locking device, it is possible to override the system for manual operations by the release knob (positioned between the high and low pressure valves) and give **1-2 turns maximum**. With reversible ie. non locking motor pumps, this operation is not required.

The gate lock is simply to be unlocked by the key and the gate pushed by hand towards the required direction.

